

Product introduction

Description

Submersible level transmitter



633PI Submersible level transmitter is designed for dealing with the most severe demanding level measurement conditions. The sensor adopts the most advanced micro-processor technology with comprehensive linear error compensation and temperature error compensation to assure the highest precision of measuring result. The probe adopts full potting condensation-preventing technology, safe and reliable dual-seal design and fully welding technology with solid stainless steel body to assure long term stability and permanent air tightness. Signal transmitting module adopts transient voltage resistance protective circuits to assure operation regularly even under the harsh surge voltage environment. The seal of the cable adopts intensive cone plug sealing design to assure the long working life even under large mechanical load conditions during the installation and long-term use. PI633 Submersible level transmitter is the optimal choice to satisfy all of high demand level measuring applications.

Main parameters

Pressure types	Gauge pressure
Measuring range	1mH ₂ O - 200mH ₂ O, Please refer to the ordering information chapter
Output signal	4-20mA, 4-20mA+HART, 0.5-4.5VDC Modbus-RTU/RS485, others
Reference accuracy	±0.2% URL, ±0.5% URL

Application

Level measurement in container, others

Approvals



Measuring medium

Water, waste water, oil

Technical specifications

Measuring range and limit

Nominal value	Smallest calibratable span	Lower range limit (LRL)	Upper range limit (URL)	Overload limit
20kPa	10kPa	0kPa	20kPa	30kPa
35kPa	20kPa	0kPa	35kPa	52.5kPa
100kPa	35kPa	0kPa	100kPa	150kPa
200kPa	100kPa	0kPa	200kPa	300kPa
700kPa	350kPa	0kPa	700kPa	1050kPa
1MPa	500kPa	0kPa	1MPa	1.5MPa
1.7MPa	1MPa	0kPa	1.7MPa	2.55MPa
*3.5MPa	1.7MPa	0kPa	2MPa	5.25MPa

*Due to the seal structure limit of the products, the upper range limit(URL) is lower than the nominal value(see chart above). (1MPa = 102 mH2O@4°C)

The unit of the measuring range above can be converted into mH2O@4°C, mmH2O@4°C, inH2O@4°C, m, mm and mHg@0°C. Please provide the density of measuring medium if the unit is m, mm. Other measuring range is available according to requirements.

Standard specifications and reference conditions

Test standard: GB/T28474 / IEC60770
Zero based-calibration span, Linear output, Silicon oil filling, 316L stainless steel isolated diaphragm.

Performance specifications

The overall performance including but not limited to **【reference accuracy】**, **【environment temperature effects】** and other comprehensive error

Typical accuracy: ±0.2% URL (HART output accuracy: ±0.1% URL)

Stability: ±0.2% URL/ year

Reference accuracy

Including linearity, hysteresis and repeatability.
calibration temperature: 20 °C ± 5 °C

Linear output accuracy	Typical	±0.2%URL (HART output accuracy: ±0.1% URL)	Nominal value: 20kPa, 35kPa, 100kPa, 200kPa, 700kPa, 1MPa, 1.7MPa, 3.5MPa
	Max/ Voltage output	±0.5% URL	

Ambient temperature effects

Within the range - 20-80 °C total impact ±0.2%URL/10k

Power supply effects

Zero and span change should not be more than ± 0.005% URL/V

Loading effects

Zero and span change should not be more than ± 0.05% URL/kΩ

Durability performance

All the measuring range, working life> 10 million pressure circulation@25°C

Vibration effects

According to IEC61298-3/GB/T 18271.3 testing 20g (5-2000HZ, Maximum vibration value< 3mm)

Output signal

Signal	Type	Output
4-20mA	Linearity	Two wire
4-20mA+HART	Linearity	Two wire
0.5-4.5VDC	Linearity	Three wire
Modbus-RTU/RS485	Linearity	Four wire

Performance specifications

Insulation resistance

≥20MΩ@, 100VDC

Damping time

Total damping time constant: equal to the sum of damping time of amplifier and sensor capsule

Damping time of amplifier: 0-100S adjustable

Startup after power off: ≤3S (HART output time: ≤ 6S)

Normal services after data recovery: ≤4S (HART output time≤31S)

Environment condition

Items	Operational condition
Working temperature	-10-70°C
Storage temperature	-30-80°C
Media temperature	-10-70°C
Protection class	IP68
Dangerous condition	ExialICT4(GYB16.1963X)*
*Only for 4-20mA output	

Technical Specifications

Signal output	4-20mA	4-20mA+HART*	0.5-4.5VDC	0.5-4.5VDC(ratiometric output)	RS485
Power supply	10-30VDC	10.5/16.5-55VDC	6-15VDC	5VDC	5VDC/9-30VDC
Allowed current	≤20.8mA		≤3.5mA		≤7mA
Load resistance(Ω)	<(U-10)/0.0208	<(U-10.5)/0.0208**	≥5k, recommend 100k		/
Transmission distance	<1000m		<5m		<1200m
Power consumption	≤500mW(20.8mA output@24VDC)		≤17.5mW(0.5-4.5VDC output@5VDC)		≤168mW(RS485 output@24VDC)

*For this output type, the load resistance value in communication is 250Ω

**The load resistance value 0-2119Ω is in nominal working condition, 250-600Ω is for HART communication

EMC environment (not for RS485 signal output)

NO.	Test items	Basic standards	Test conditions	Performance level
1	Radiated interference	GB/T 9254/CISPR22	30MHz-1000MHz	OK
2	Conducted interference (DC power port)	GB/T 9254/CISPR22	0.15MHz-30MHz	OK
3	Electrostatic discharge immunity test (ESD)	GB/T 17626.2/IEC61000-4-2	4kV(Contact), 8kV(Air)	B(Note2)
4	Immunity to radio frequency EM-fields	GB/T 17626.3/IEC61000-4-3	10V/m(80MHz-1GHz)	A(Note1)
5	Power frequency magnetic field Immunity test	GB/T 17626.8/IEC61000-4-8	30A/m	A(Note1)
6	Electrical fast transient / Burst Immunity Test	GB/T 17626.4/IEC61000-4-4	2kV(5/50ns, 100kHz)	B(Note2)
7	Surge immunity requirements	GB/T 17626.5/IEC61000-4-5	1kV(Line to line) 2kV(Line to ground) (1.2us/50us)	B(Note2)
8	Immunity to conducted disturbances induced by radio frequency fields	GB/T 17626.6/IEC61000-4-6	3V(150kHz-80MHz)	A(Note1)

(Note 1)Performance level A: The performance within the limits of normal technical specifications.

(Note 2)Performance level B: Temporary reduction or loss of functionality or performance, it can restore itself. The actual operating conditions, storage and data will not be changed.

Product selection instruction

Sensor select instruction

Code	Nominal value	Description
L203G	20kPa	Range 0-20kPa Smallest calibratable span 10kPa
L353G	35kPa	Range 0-35kPa Smallest calibratable span 20kPa
L104G	100kPa	Range 0-100kPa Smallest calibratable span 35kPa
L204G	200kPa	Range 0-200kPa, Smallest calibratable span 100kPa
L704G	700kPa	Range 0-700kPa Smallest calibratable span 350kPa
L105G	1MPa	Range 0-1MPa Smallest calibratable span 500kPa
L175G	1.7MPa	Range 0-1.7MPa Smallest calibratable span 1MPa
L355G	3.5MPa	Range 0-2MPa Smallest calibratable span 1.7MPa

Code	Position	Description
S	Isolated diaphragm material	SUS316
S	Isolated filling fluid	Silicon oil, process temperature: -45-205°C
S	Sensor seal	O-ring, FKM, process temperature: -20-200°C
F		Stainless steel welding seal

Seal (S)

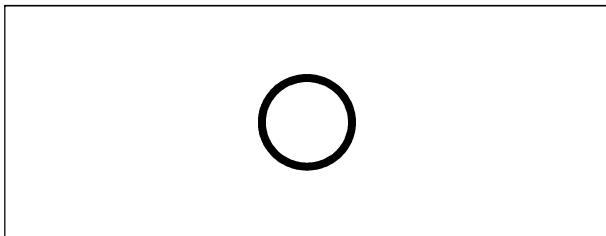

Electrical connection

Code	Item	Description
N1	Electrical connection	PUR cable, outer diameter (7.5±0.2)mm
N2		PTFE cable, outer diameter (7.5±0.2)mm

Cable(N1/N2)

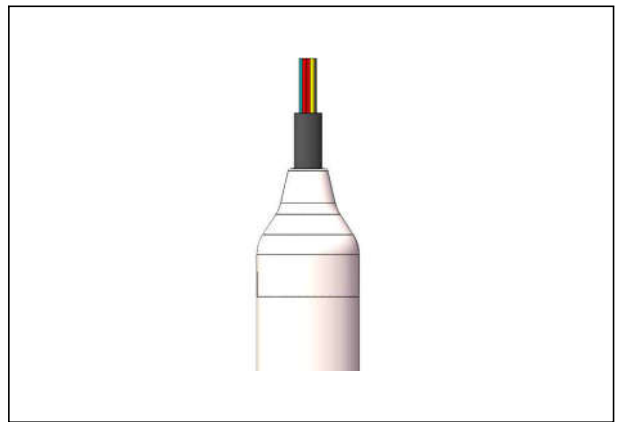

Electrical connection

Cable output

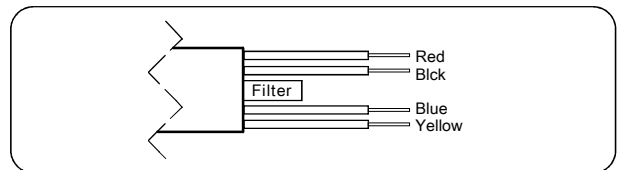

Label	Two wires	Three wires	Four wires	Modbus-RTU/RS485
Red	Power+	Power+	Power+	Power+
Black	Power-	Power-	Power-	Power-
Blue		Signal+	Signal+	A+
Yellow			Signal-	B-

⚠ The reference pressure of the gauge pressure transmitter is current atmospheric pressure.
Please operate with care, prevent the filter dropping off and keep it dry

Product selection instruction

Transmission module

Code	Description
F	4-20mA two wire, power supply: 10-30VDC
H	4-20mA+HART two wire, power supply: 16.5-55VDC
5	0.5-4.5VDC three wire, power supply: 6-15VDC
6	0.5-4.5VDC ratiometric output three wire, power supply: 5VDC
R	Modbus-RTU/RS485, four wire, power supply: 5VDC/9-30VDC

Fixed mounting accessory

Code	Items	Details
P1	Fixed mounting	Counter weight (To fix products in some areas of fast flow rate or medium with large density)
P2		Cable clamp (To fix and support the product)
P3		Thread connection (To fix the top and support the product)
P4		Thread connection (To fix the bottom and support the product)

Counter weight(P1), Cable clamp(P2), Thread connection(P3)

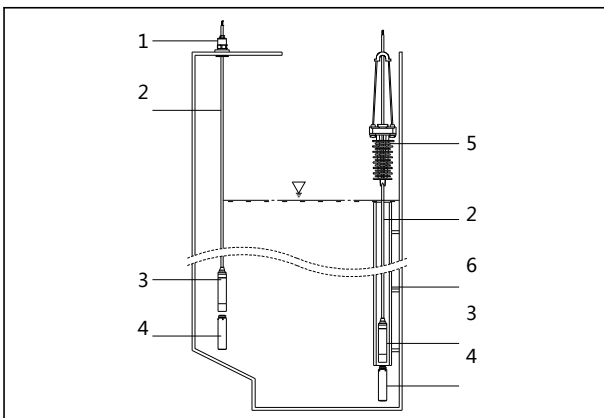

- 1. Thread connection(P3)
- 2. Cable
- 3. Level transmitter
- 4. Counter weight(P1)*
- 5. Cable clamp(P2)
- 6. Protective sleeve

*The measurement results should consider the height error of counter weight and sensing diaphragm to the bottom of measured medium

Disclaimer: all the data used in the product description is not legally binding. Relevant technical details may be changed due to further improve

Electrical connection

Code	Item	Description
4	Material	Stainless steel, SUS304
6		Stainless steel, SUS316
H28	Specification	Diameter of submersible probe: 28mm

Probe diagram(H28)

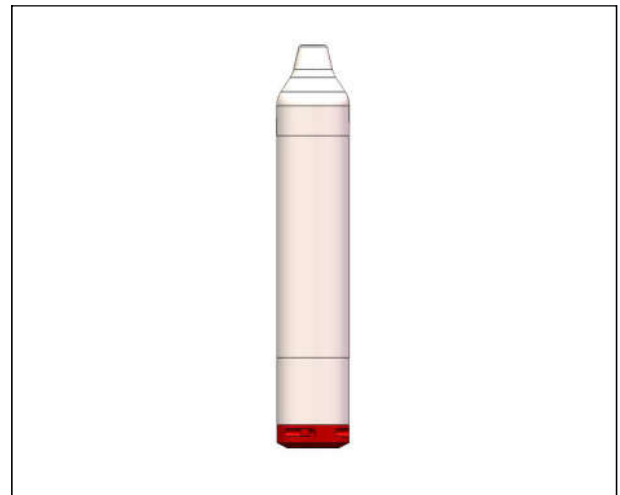

Thread connection(P4)

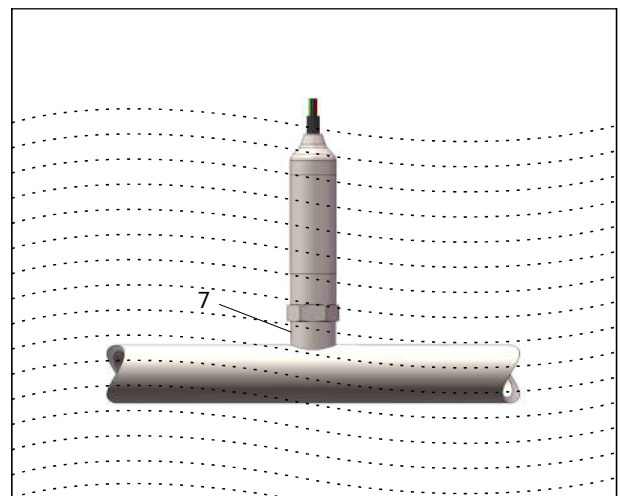

- 7. Thread connection(P4)

Product drawing and dimension

Drawing and dimension (unit:mm)

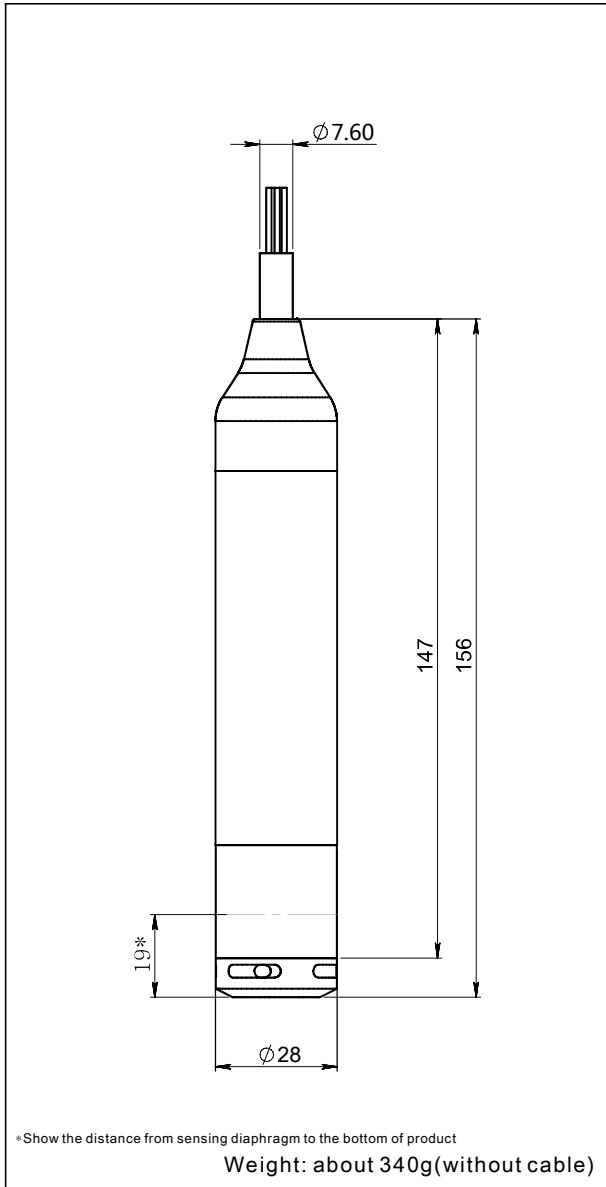

Counter weight drawing and dimension(P1)(unit:mm)

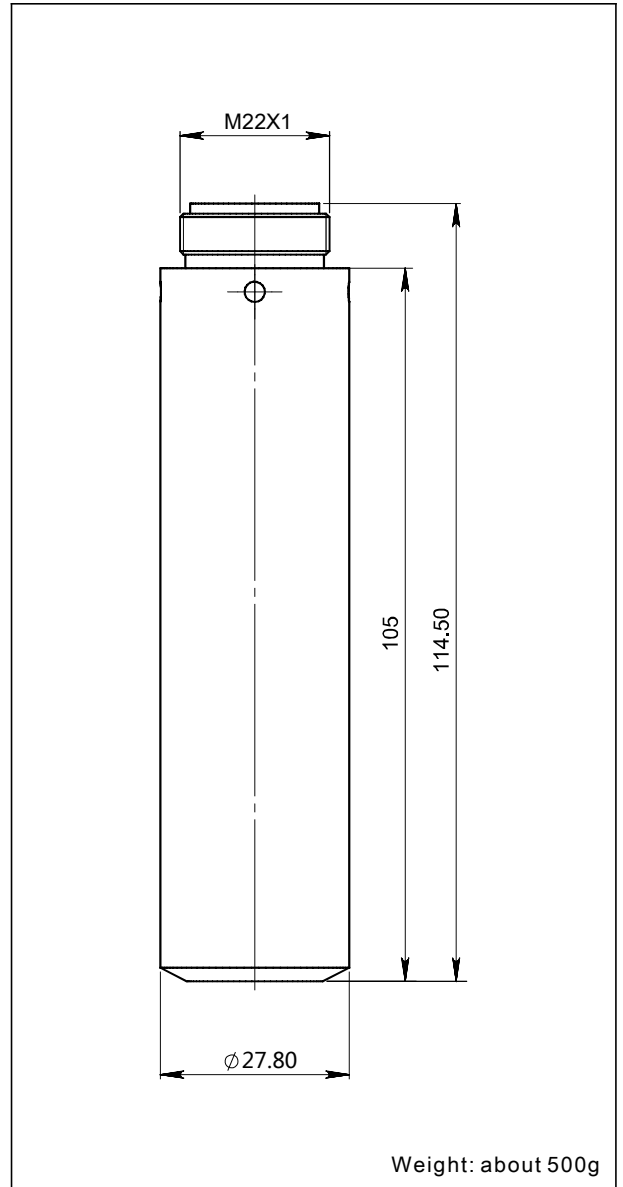

Cable Weight Table

Cable material	Weight/5m(kg)
Polyurethane(PUR)	0.32
Polytetrafluoroethylen(PTFE)	0.41

In order to prevent measurement errors caused by sideways movement of product and ensure accuracy, you can add additional counter weights by screwing together and then connecting directly to the product. Each product can be added three counter weights at the most.

Product drawing and dimension

Cable clamp (P2) drawing and dimension (Unit:mm)

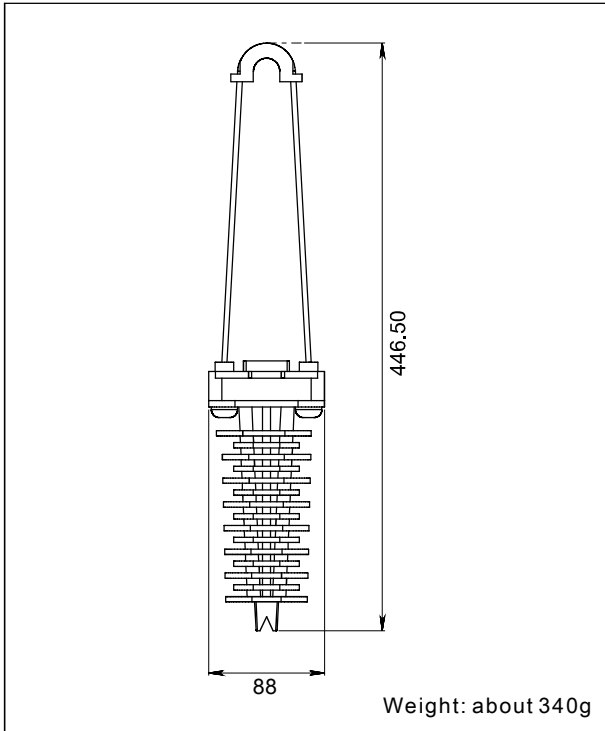

Thread connection (P4) drawing and dimension (Unit:mm)

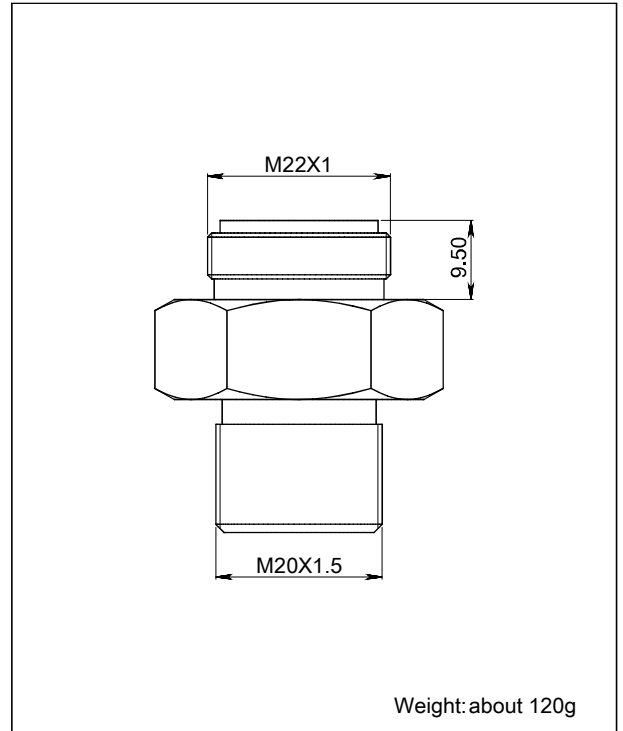

Thread connection mounting (P3) drawing and dimension (Unit:mm)

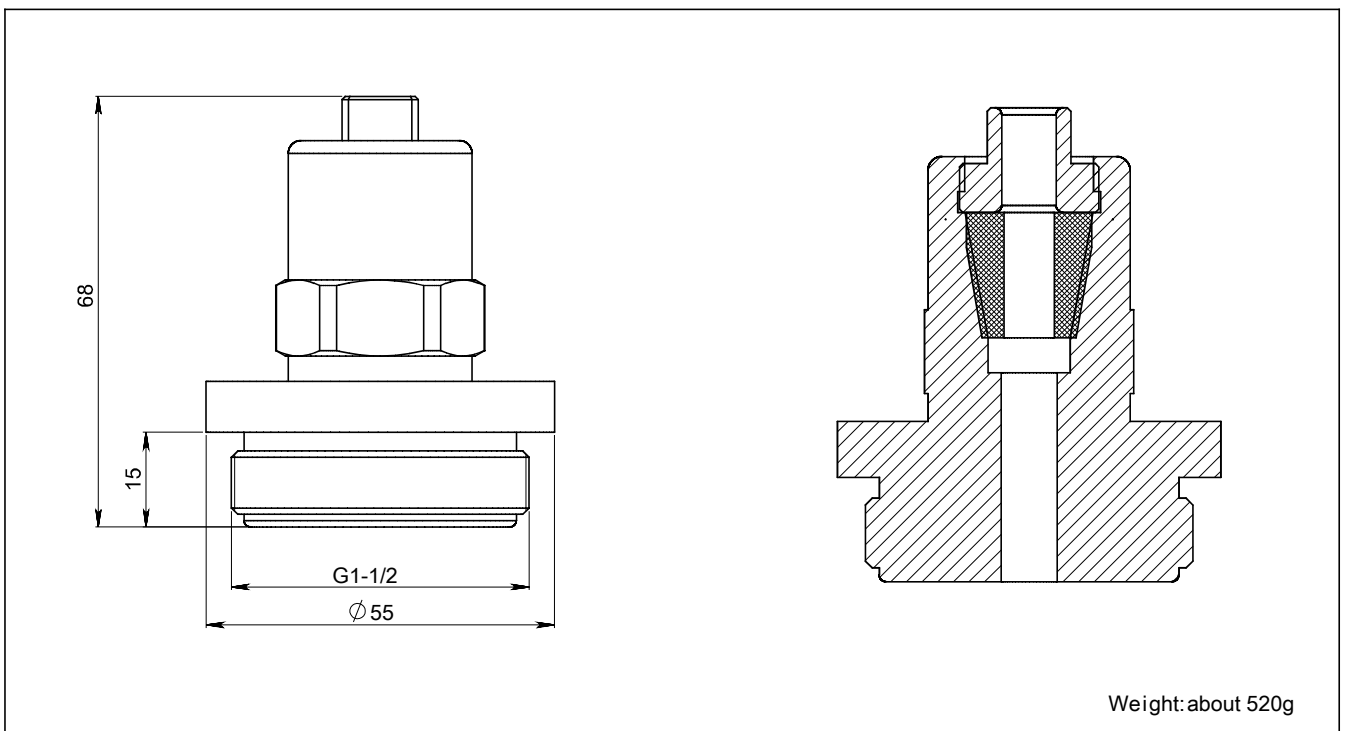

Ordering information chapter

Item	Parameters	Code	Instruction	(*) fast delivery available
	Model	633PI-LN	Piezoresistive silicon submersible level transmitter	
Sensor	Separator	-	Detailed specifications as following	
	Pressure range code	L203G	Nominal value(URL): 20kPa	
		L353G	Nominal value(URL): 35kPa	
		L104G	Nominal value(URL): 100kPa	*
		L204G	Nominal value(URL): 200kPa	*
		L704G	Nominal value(URL): 700kPa	*
		L105G	Nominal value(URL): 1000kPa	*
		L175G	Nominal value(URL): 1700kPa	*
		L355G	Nominal value(URL): 3.5MPa	
	Isolated diaphragm material	S	Stainless steel, SUS316	*
	Isolated filling fluid	S	Silicon oil, process temperature: -45-205°C	*
Sensor seal	S	O-ring, FKM, process temperature: -20-200°C	*	
	F	Stainless steel welding seal		
Electrical connection	Separator	-	Detailed specifications as following	
	Electrical connection	N1	PUR cable, outer diameter: (7.5±0.2)mm	*
		N2	PTFE cable, outer diameter: (7.5±0.2)mm	
	Cable entry protector	R0	None	*
Output	Separator	-	Detailed specifications as following	
	Output signal	F	4-20mA two wire, power supply: 10-30VDC	*
		H	4-20mA+HART two wire, power supply: 16.5-55VDC	*
		5	0.5-4.5VDC three wire, power supply: 6-15VDC	
		6	0.5-4.5VDC ratiometric output three wire, power supply: 5VDC	*
		R	Modbus-RTU/RS485 four wire, power supply: 5VDC/9-30VDC	
		G	Modbus-RTU/RS485 four wire (with pressure and temperature signal), power supply: 5VDC/9-30VDC	
Probe	Separator	-	Detailed specifications as following	
	Material	4	Stainless steel, SUS304	*
		6	Stainless steel, SUS316	*
	Specification	H28	Submersible probe diameter 28mm	*
Cable	Separator	-	Detailed specifications as following	
	Cable length	Ln	0 ≥ n ≤ 200, Eg. 5 m=L5, 10m = L10, 100m=L100. Allowed error range: 0-0.2m.	*

Ordering information chapter

Additional options	Separator	-	Detailed specifications as following	
	Fixed mounting accessory	/P1	Counter weight (To fix products in some areas of fast flow rate or medium with large density), M22*1(M), SUS304	*
		/P2	Cable clamp (To fix and support the product), PVC	
		/P3	Thread connection (To fix the top and support the product), G1-1/2(M), SUS304	*
		/P4	Thread connection (To fix the bottom and support the product), M22*1(M) change to M22*1.5(M), SUS304	*
	Calibration report	/Q1	According to user requirements	*
	Approvals (multiple)	/I1	Intrinsic safety certificate, ExialICT4, NEPSI	
		/F3	CE certificate	
	Wetted parts treatment	/G1	Ungrease treatment	
/G2		Electropolishing treatment		

Approvals

Factory certificate

Certification organization	Intertek
Quality management system	ISO9001-2008
Scope of certification	Design and production of pressure transmitter
Registration number	110804039

CE

Certificate organization	ISET
License scope	633PI series submersible level transmitter
Mark	CE
EMC instruction	2014/30/EU
Standard	EN61326-1: 2013
Registration number	IT021353LG161207

Intrinsic safety certificate

Certification organization name	NEPSI
Licenses range	633PI series submersible level transmitter
Explosion-proof mark	ExialICT4
Ambient temperature	-40-+60°C
Medium maximum temperature	+120°C
Registration number	GYB16.1963X
Intrinsically safe parameter description	Maximum input voltage: 28VDC
	Maximum input current: 100mA
	Maximum input power: 0.7w
	Maximum internal equivalent parametersCi(uF): 0.04
	Maximum internal equivalent parametersLi(mH): 1.8

Level Measurement Expert

Prisma Instruments
Expertise & Industrial Solutions

Prisma Instruments
89, rue du Vallat 13400 Aubagne
FRANCE

Tel. : +33 (0)4 42 70 74 04
Fax : +33 (0)4 42 70 38 64 @ :
contact@prisma-instruments.com